

RZM 13-1400

Technical Data

RZM 13-	Nominal motor power kW	Poles	Motor size	Motor voltage V	Phases	Nominal frequency Hz	Connection	Nominal motor current A	Nominal motor speed 1/min	Max. fan speed 1/min	Max. operating frequency Hz	Weight kg
1400-8D-50	90	8	315L	400	3~	50	△	168	738	770	52	2915
1400-8D-51	110	8	315L	400	3~	50	△	205	738	820	55	3025
1400-8D-52	132	8	315L	400	3~	50	△	245	738	875	59	3135
1400-8D-53	160	8	315	400	3~	50	△	295	739	925	62	3235

Motor code:

- W = Asynchronous motor (efficiency class IE2)
- D = Asynchronous motor

Dimensions in mm, subject to change.

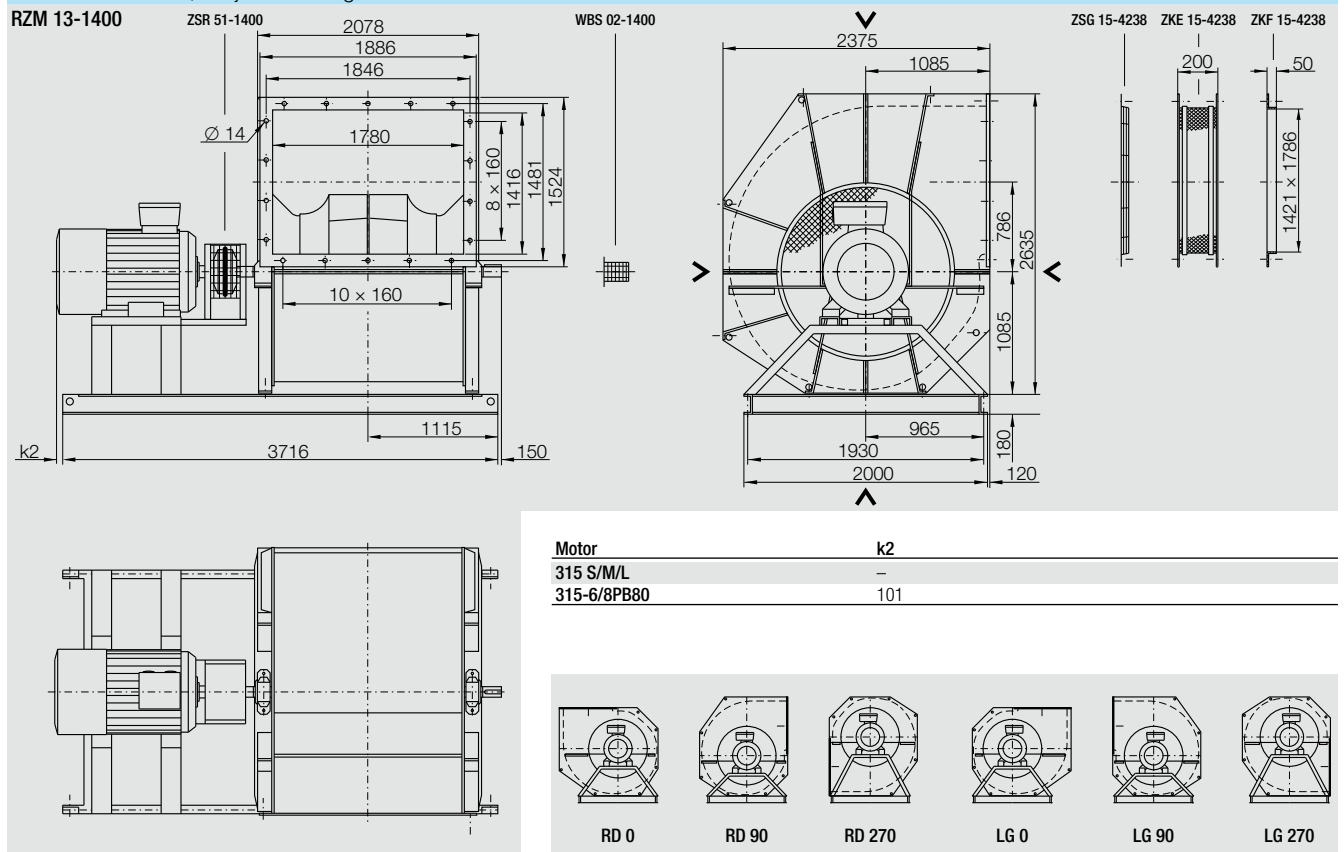

Accessories

RZM 13-	Frequency inverter 6SE6430-	Control Panel for frequency inverter 6SE6420- and 6SE6430-	Line Choke for 3~	Interference Suppression Filter - Class A
1400-8D-50	6SE6430-2AD38-8FA0	6SE6400-0BE00-0AA0	6SE6400-3CC11-7FD0	-
1400-8D-51	6SE6430-2UD41-3FA0	6SE6400-0BE00-0AA0	6SL3000-OCE32-8AA0	6SL3000-0BE34-4AA0
1400-8D-52	6SE6430-2UD41-6GA0	6SE6400-0BE00-0AA0	6SL3000-OCE33-3AA0	6SL3000-0BE34-4AA0
1400-8D-53	6SE6430-2UD42-0GA0	6SE6400-0BE00-0AA0	6SL3000-OCE35-1AA0	6SL3000-0BE34-4AA0